

LIDAN



Subsea

Within this segment Lidan Marine supplies Launch and Recovery Systems for ROV's designed for submersion down to 6 000 meters' depth. A vast range of umbilical winches, cranes, overhead travelling systems and A-frames has been proven to complete reliability. To increase the equipments accessibility in the toughest of sea conditions Lidan Marine has launched a top-of-the-line AHC technology. The company also provides submersible control and safety systems for the Seismic industry.

Industry

Lidan Marine supplies tailored winch and handling systems. Examples are high resolution test equipment for helicopters rescue hoists and winches for heavy vehicle test ranges with extreme speed control requirements. The company also supplies a broad range of winches for heavy door handling including redundant safety systems.

Naval

Lidan Marine is one of the world's leading suppliers of advanced handling equipment for naval vessels. The company has focused on proving dependable multi purpose systems that are light and compact. The customers can access a wide portfolio of proven technology for handling equipment in the area of MCM and ASW.

RoRo

Lidan Marine is, by supplying roughly 70 % of the world market, the global leader in deign and manufacture of handling equipment for heavy stern and side ramps for deeps sea RoRo vessels. This larger class of ships usually handles more than 2 500 car equivalent units. The customers require that the systems are equipped with constant tension technology compensating for tide, sea heave and cargo loading and unloading.

Lidan Marine AB

Box 854 SE-531 18 Lidköping, Sweden

Visit address: Fiskaregatan 3

Phone: +46(0)510 54 52 50

Email: info@lidanmarine.com



WROV A-Frame SWL 10 ton

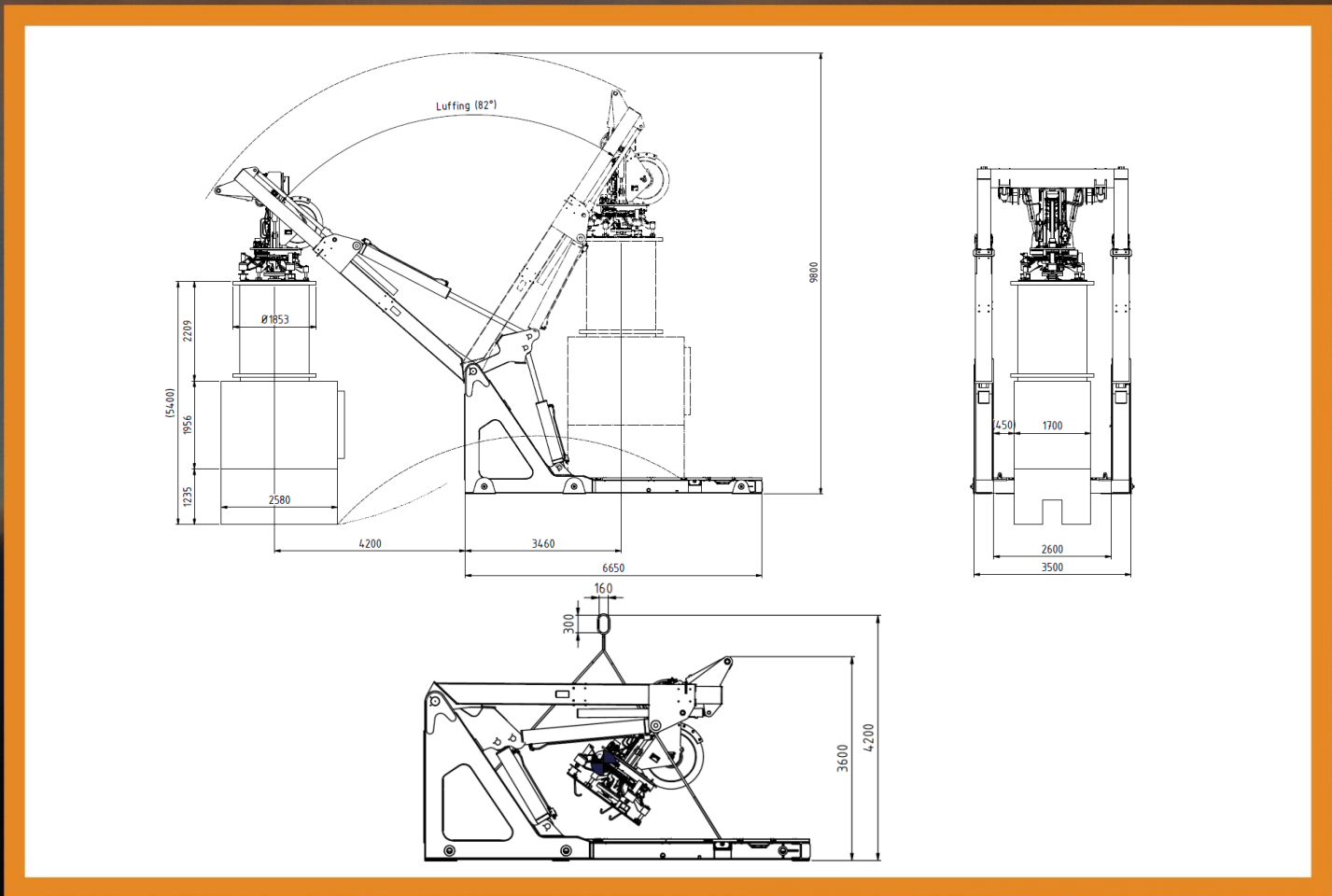

WROV A-Frame SWL 10 ton

The equipment is designed in accordance with DNV Standard for Certification No. 2.22 Lifting Appliances, June 2013 and No. 2.7-3 Portable Offshore Units, May 2011.

Snubber Characteristics:

Snubber rotation:	Yes
Snubber tilt:	Yes
Latch:	Yes

A-Frame and Skid Characteristics

SWL:	10 ton (22046lbs)
Footprint dimensions:	6,6 x 3,4 m
Outreach:	4.200 m
Width between A-frame legs	2.6 m



Watch demonstration of
Active Heave Compensation

Lidan Marine AB
Box 854 SE-531 18 Lidköping, Sweden
Visit address: Fiskaregatan 3
Phone: +46(0)510 54 52 50
Email: info@lidanmarine.com